

WebMaster® ONE

Cooling Tower/Boiler Controller

ONE simple and flexible controller for ALL your water treatment needs!

Walchem's WebMasterONE integrates advanced sensing, instrumentation, fluid handling, and data communications technologies to bring you the most sophisticated cooling tower & boiler controller in the water treatment industry.

The simple, intuitive programming makes it easy to configure your WebMasterONE to control multiple cooling towers, boilers, closed loops, or virtually any water treatment process. It will monitor and control based on a wide range of direct sensor inputs as well as measurement inputs from other devices such as corrosion, level, temperature and pressure. WebMasterONE is on duty 24 hours a day, 365 days a year, keeping on-site and off-site personnel notified of system performance, all the while providing comprehensive and reliable water treatment control.



SUMMARY OF KEY FEATURES



- ▶ Easy to start-up and use - with just a web browser!
- ▶ Extensive built-in Plug & Play communications options:
 - Ethernet
 - USB (laptop & flash disk support)
 - Cell modem
 - Landline modem
- ▶ VTouch® provides quick, centralized 24/7 awareness of account status with the ability to LIVE Connect to any of your controllers in the field with one simple mouse-click.
- ▶ System status reports and datalog files can be sent automatically
- ▶ PPM set points with feed verification
- ▶ Instant alarm notification via email, cell phone text message or local alarm relay
- ▶ Wide range of direct sensor measurements:
 - pH
 - ORP
 - Conductivity
 - Electrodeless conductivity
 - Free chlorine/bromine
 - Chlorine dioxide
- ▶ Modbus read/write is available for seamless integration with building energy management, distributed control, process management and SCADA systems
- ▶ Protect the building's infrastructure while conserving water, energy and chemicals

Innovation

WebMasterONE® is the most advanced online process controller in the water treatment industry. It supports all global communications standards:

- USB plug-n-play for local laptop communications (standard feature)
- Ethernet for LAN communications (standard feature)
- Internal analog modem (optional)
- Internal cellular modem utilizing the latest global standard digital technologies (GPRS) used by most major cellular carriers (optional)



Simplicity

True innovation has made WebMasterONE® the easiest controller to use! To communicate with WebMaster ONE®, simply connect the USB cable to your laptop, open a standard web browser, and type in the WebMaster default address. That's it! You're connected to the WebMasterONE® and surfing the pages just like a website.

Convenience

Walchem's patented ShoulderTap® technology (Internet Connectivity On Demand) allows WebMasterONE® to be monitored and controlled over the Internet from any computer, anywhere in the world, with a standard web browser, without the need to be on the Internet at all times. No proprietary software, no long distance phone charges, and it's completely safe since the controller is only connected to the Internet when you request it, or when it sends out reports and alarms.

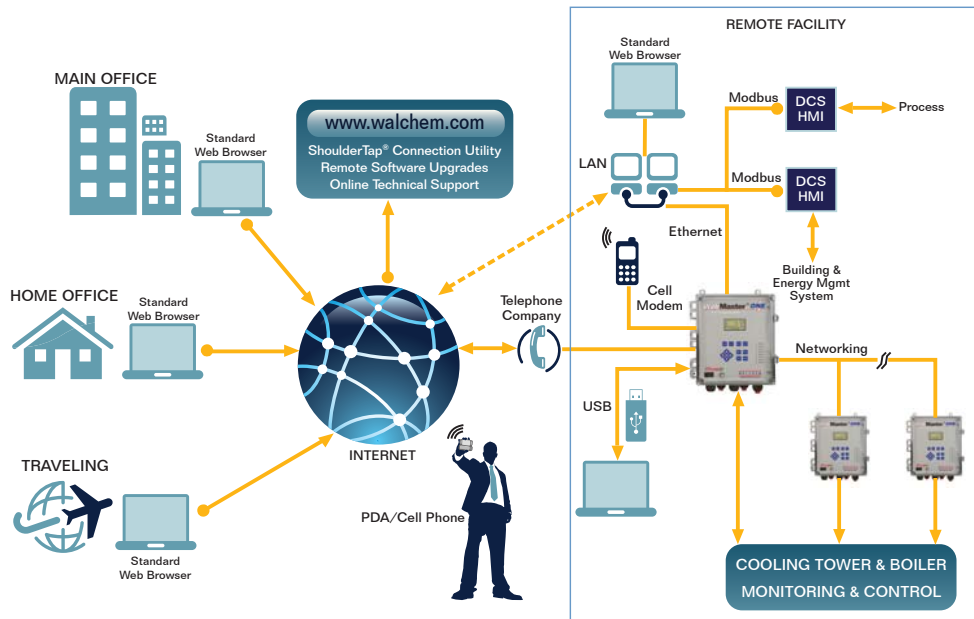

Flexibility

WebmasterONE® allows you to control cooling towers, boilers, closed loops, condensate lines, wastewater systems or any combination using one controller. All standard water treatment control methods are included in every WebMasterONE®: Biocide timers, On/Off and Time Proportional Control, Inhibitor feed, Intermittent boiler sampling with flashing detection, ORP control with periodic spike, and many others.

Compatibility

WebMasterONE® supports many of the most popular global communications standards:

- MODBUS TCP/IP(Ethernet) - Seamless connectivity to building energy management, distributed control, process management and SCADA systems
- SMTP- EMAIL for sending alarms, reports, or data log files
- ETHERNET
- Cell phone text messaging for instant, descriptive text message alarms
- Networking: Ethernet based networking allows the use of a single phone line or cell modem for communicating with multiple controllers at one site, even when they are located in different buildings!

Reliability

Every part of WebMasterONE® has been designed for reliable performance in any application:

- Industrial grade pH/ORP/Conductivity sensors
- Rugged flow switch manifold
- UL, CSA and CE safety and electromagnetic performance approvals reduce electrical safety liability concerns and dramatically reduce electrical noise and powerline related field problems



Receive alarms via cell phone text messaging



Receive spreadsheet datalogs as an attachment to an email at user-defined time periods.

MEASUREMENT PERFORMANCE

	Range	Resolution	Calibration
Contacting Conductivity	10 to 10,000 $\mu\text{S}/\text{cm}$	1 $\mu\text{S}/\text{cm}$	$\pm 50\%$ of raw reading (scalable to ppm)
pH	-2 to 16 pH	0.01 pH	Single or Dual Point
ORP	-1400 to 1400 mV	1 mV	Single or Dual Point
Temperature	0 to 200°C (32 to 392°F)	1°C (1°F)	Single Point
Electrodeless Conductivity	1000 to 10,000 $\mu\text{S}/\text{cm}$	1 $\mu\text{S}/\text{cm}$	Single or Dual Point (scalable to ppm)
Free Chlorine/Bromine	0 to 8 mg/l (PPM)	0.01 mg/l	Single Point and Zero
Chlorine Dioxide	0 to 10 mg/l (PPM)	0.01 mg/l	Single Point and Zero

INPUTS

Power

100-120/220-240 VAC $\pm 10\%$
12 amp, 50/60 Hz
Fuse 1.6A, 5 x 20mm

Sensors (1 standard, up to 4 optional)

Signal: ± 1.4 VDC (isolated)
Temperature: 1Kohm, 10 Kohm or 100 Kohm

Digital Inputs (6 standard, additional 6 optional)

Isolated dry contact, 0-300 Hz, 1.5 msec minimum width

Analog (4-20 mA) Inputs (8 optional)

2 or 3 wire, internally powered by 24 VDC loop power available, 25 ohm input resistance, 1000 ohm maximum load

OUTPUTS

Mechanical relays (8 standard)

115VAC, 10 amp resistive, 1/8 HP
230VAC, 6 amp resistive, 1/8 HP
May be dry contact or powered by line voltage.
R1-R4 fused together, current not to exceed 5.5 amp
R5-R8 fused together, current not to exceed 5.5 amp
Only powered relays are fused. N.O. and N.C. contacts provided.

Analog (4-20 mA) Outputs (up to 4 optional)

Isolated, 500 ohm maximum load, internally powered by 24 VDC

MECHANICAL

Enclosure: Thermoplastic
NEMA Rating: NEMA 4X
Display: 64 x 128 pixel backlit LCD
Ambient Temp: 0 to 49°C (32 to 120°F)
Storage Temperature: -29 to 80°C (-20 to 176°F)
Shipping Weight: Approx. 5.4kg (12 lb)

SENSOR SPECIFICATIONS

Sensor	Range	Temperature	Pressure	Process Connection	Materials
Electrodeless Conductivity	1000 to 10,000 $\mu\text{S}/\text{cm}$	32 to 158°F	0 to 140 psi	1" NPTM submersion 2" NPTM in-line adapter	CPVC, FKM in-line o-ring
pH	-2 to 16 pH	50 to 158°F	0 to 100 psi	1" NPTM submersion 3/4" NPTF in-line tee	CPVC, Glass, FKM o-rings, HDPE, Titanium rod, glass filled PP tee
ORP	-1400 to 1400 mV	32 to 158°F	0 to 100 psi	1" NPTM submersion 3/4" NPTF in-line tee	CPVC, Glass, FKM o-rings, HDPE, Titanium rod, glass filled PP tee
Contacting Conductivity (High Pressure Tower)	10 to 10,000 $\mu\text{S}/\text{cm}$	32 to 392°F	0 to 300 psi	3/4" NPTM	316 SS, PEEK
Contacting Conductivity (High Pressure Boiler)	10 to 10,000 $\mu\text{S}/\text{cm}$	32 to 392°F	0 to 250 psi	3/4" NPTM	316 SS, PEEK
Contacting Conductivity (Graphite)	10 to 10,000 $\mu\text{S}/\text{cm}$	32 to 158°F	0 to 140 psi	3/4" NPTF tee	Graphite, glass-filled PP, FKM o-ring
Contacting Conductivity (SS)	10 to 10,000 $\mu\text{S}/\text{cm}$	32 to 158°F	0 to 140 psi	3/4" NPTF tee	316 SS, glass-filled PP, FKM o-ring
pH (High Pressure)	0 to 14 pH	32 to 275°F	0 to 300 psi	1/2" NPTM gland	Glass, Polymer, PTFE, 316 SS, FKM
ORP (High Pressure)	-1400 to 1400 mV	32 to 275°F	0 to 300 psi	1/2" NPTM gland	Platinum, Polymer, PTFE, 316 SS, FKM
Flow Switch Manifold Assy	Open < 0.7 gpm	32 to 140°F	150 psi up to 100°F 50 psi @ 140°F	3/4" NPTF	Glass-filled PP, PVC, FKM, Isoplast
Flow Switch Manifold Assy (High Pressure)	Open < 0.75 gpm	32 to 158°F	0 to 300 psi	3/4" NPTF	Carbon steel, Brass, 316 SS, FKM
Free Chlorine/Bromine	0 to 8 mg/l (PPM)	32 to 113°F	0 to 15 psi	3/4" NPTF	PVC, PTFE, Nylon, Isoplast, FKM
Chlorine Dioxide	0 to 10 mg/l (PPM)	32 to 122°F	0 to 15 psi	3/4" NPTF	PVC, PTFE, Nylon, Isoplast, FKM

VTouch is a collection of technologies designed for companies offering managed water treatment services. The VTouch solution allows service companies to more effectively manage remote accounts by significantly reducing the complexities associated with the deployment of water treatment service programs based around communicating products.

The VTouch Account Manager is fully synchronized with Walchem's web based controllers, making set-up and configuration simple and fast. Just specify the type of remote communications needed for new or existing controllers and Walchem takes care of the rest. No need to sort out and track complicated and constantly moving cellular data or dial-up ISP plans from large companies with poor customer service and unpredictable monthly charges. VTouch solves these problems by bundling the communications services, giving you a completely turn-key solution.

The innovative, fully synchronized nature of VTouch provides you with a quick, centralized 24/7 awareness of account status with the ability to LIVE Connect to any of your controllers in the field with one simple mouse-click, regardless of connection type! No phone numbers or IP addresses to remember.

VTouch Account Manager: 'Smart' Service

- On-line, web-based summary of account status
 - Process values continuously updated including past 24 hour min, max and average values
 - Alarm status
- One-click LIVE Connect to any device in the field for full view and reconfiguration
 - Analysis, troubleshooting, adjustments
- Seamlessly organize devices according to a process(es), facility, customer, etc.
- User "access" and "permissions" management
- Eliminates surprises during 'routine' visits
- Makes service PROACTIVE not reactive
- SAVES TIME! Plain & Simple

Summary view of all monitored systems

Custom named facilities (points to 'Best Hotel')

Custom 'processes' defined for each facility (points to 'Cooling Tower - Process Cooling' and 'Boiler - WM1')

Critical process data, units & custom names sent from devices, synchronized automatically in VTouch. No lengthy set-up required! (points to the data table for 'Wastewater - Plant 1')

One click and you connect LIVE to your device, regardless of connection type. (points to the phone icon for 'Wastewater - Plant 1')

Processes						
Best Hotel						
Cooling Tower - Process Cooling						
Last Value	Alarms	Conductivity Sensor (Measure) (µS)	Backup Conductivity (Measure) (µS)	ORP (Measure) (mV)	Flow Switch (State) ()	
8/18/09 5:32:53 PM	●	1218.74	1206.13	-329.27	Flow	
Best Hotel 2						
Boiler - WM1						
Last Value	Alarms	Boiler 1 (Measure) (µS)	Boiler 1 (Minimum) (µS)	Boiler 1 (Maximum) (µS)	Boiler 1 (Average) (µS)	Feedwater Flow (Total) (gal)
8/18/09 5:32:27 PM	●	3131.75	3019.82	3436.33	3318.16	2102144.75
Wastewater - Plant 1						
Last Value	Alarms	Influent pH (pH)	Effluent pH (pH)	Level (gal)	Flow (Total) (gal)	Effluent ORP (mV)
8/18/09 5:32:27 PM	●	5.41	7.31	2416.00	26243.00	-251.60

Communications

With an embedded web server, WebMasterONE utilizes standard TCP/IP Internet communications. Remote communications can be established with WebMasterONE via the Internet or on a direct line with modem-to-modem capability. USB Plug and Play and Ethernet are included to allow easy on-site access for plant personnel and system operators. Multiple users can access the controller simultaneously. A graduated password protection system allows users varied degrees of access from view only to full system configuration. In addition, WebMasterONE delivers a range of user-friendly information reporting tools including email notifications for datalogs, alarms and system summaries.

Walchem has made use of the Internet as a remote access communications platform for industrial control equipment a practical reality. While others just attempt to reduce the cost of embedded web server hardware, Walchem has solved the problem of the high cost and lack of availability of a permanent connection to the Internet.

WebMasterONE makes programming your cooling tower or boiler simple and fast and WebMasterONE does not require any proprietary software to reside on your computer. Set-up and programming are all done via a standard web browser.

Easy to follow menus and system set-up screens make programming user friendly and intuitive. Once WebMasterONE is installed, the Start-up menu jump-starts you through the top level set-up. The Input, Output and utility menus guide you through the rest of the programming.

- **USB Plug and Play:** For local monitoring and reconfiguration of your WebMasterONE via Laptop or dedicated on-site PC.
- **ShoulderTap® Internet Communications:** For monitoring and reconfiguration of your WebMasterONE remotely via the Internet (requires landline modem card option).
- **DirectTap Modem-to-Modem:** For remote monitoring and reconfiguration of your WebMasterONE using traditional modem-to-modem communications (requires landline modem card option).
- **Ethernet:** For monitoring and reconfiguration of your WebMasterONE via Local Area Network or remotely via the Internet
- **Cellular:** For monitoring and reconfiguration of your WebMasterONE remotely via the Internet (requires cell modem and VTouch option).

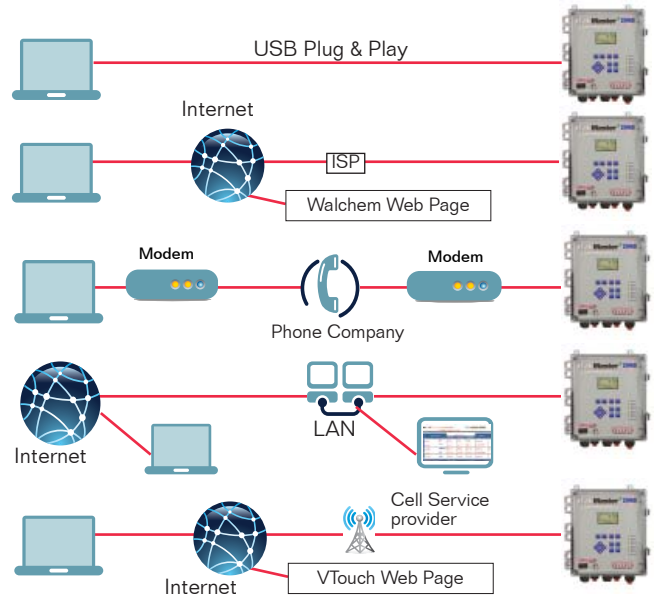

ETHERNET NETWORKING

Walchem's Ethernet Networking allows you to leverage the power of the WebMasterONE communications abilities. By using the Local Area Network (LAN) or by connecting the WebMasters together via Ethernet, you can access all the controllers on the network from a single phone line. It's simple. Each controller includes Ethernet and the Master controller requires the Ethernet Networking "Master" capability. Utilizing a Master-Slave type relationship - one controller is configured to be the Master or window to all the other units (Slaves) on the network.

By utilizing the existing LAN, wiring can be minimized. The controller simply plugs into the nearest LAN connection via a standard Ethernet cable. The Master controller detects the other Walchem devices on the network and provides a single point of access.

Modbus TCP/IP (Ethernet) is available to seamlessly connect to building energy management, distributed control, process management and SCADA systems.

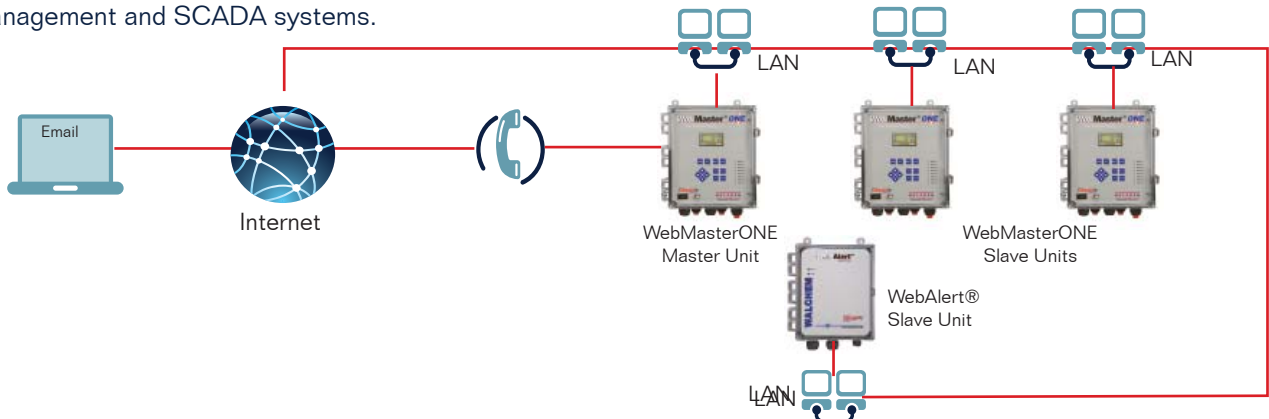

Sensor Selection

1 WMT8 SINGLE COOLING TOWER

A System Cond

- 0 = No sensor
- 1 = Graphite electrode, 150 psi
- 2 = Electrodeless, 150 psi
- 3 = SS electrode, 150 psi
- 4 = High pressure, 300 psi

B pH/ORP

- 0 = None
- 1 = pH, flat, 100 psi
- 2 = ORP, rod, 100 psi
- 3 = Both, 100 psi
- 4 = pH, bulb, high pressure, 300 psi
- 5 = ORP, high pressure, 300 psi
- 6 = Both, 300 psi

C Makeup Cond

- 0 = None
- 1 = Graphite electrode
- 2 = Electrodeless
- 3 = SS electrode
- 4 = High pressure, 300 psi

2 WMB8 BOILER

A Boiler #1 Conductivity Sensor

- 0 = None
- 1 = 250 psi

B Boiler #2 Conductivity Sensor

- 0 = None
- 1 = 250 psi

C Boiler #3 Conductivity Sensor

- 0 = None
- 1 = 250 psi

D Boiler #4 Conductivity Sensor

- 0 = None
- 1 = 250 psi

3 WMD8 DUAL COOLING TOWER

Tower #1(A) and Tower #2 (C) System Conductivity

- 0 = No electrode
- 1 = Graphite electrode
- 2 = Electrodeless
- 3 = SS electrode
- 4 = High pressure

Tower #1 (B) and Tower #2 (D) 2nd Sensor

- 0 = No sensor
- 1 = pH, flat
- 2 = ORP, rod
- 3 = pH, High pressure
- 4 = ORP, High pressure
- 5 = Contacting cond, graphite
- 6 = Contacting cond, high pressure

4 WM18 MIXED PURPOSE

A number of sensor inputs required

- 1 = One sensor input
- 2 = Two sensor inputs
- 3 = Three sensor inputs
- 4 = Four sensor inputs

Sensor Selection

- 1 WMT8 A B C – E F G H J K **Single Cooling Tower**
- 2 WMB8 A B C D – E G H J K **Boiler**
- 3 WMD8 A B C D – E F G H J K **Dual Cooling Tower**
- 4 WM18 A – E G H J K **Mixed Purpose**

System Options

System Options

E VOLTAGE CODE (ALL MODELS)

- 0 = Prewired, 0 powered, 8 dry contact relays
- 1 = Prewired, 7 powered, 1 dry contact relays
- 2 = Prewired, 8 powered, 0 dry contact relays
- 3 = Prewired, 4 powered, 4 dry contact relays
- 4 = Hardwired, 0 powered, 8 dry contact relays
- 5 = Hardwired, 8 powered, 0 dry contact relays
- 6 = Hardwired, 7 powered, 1 dry contact relays
- 7 = Hardwired, 4 powered, 4 dry contact relays

F FLOW SWITCH OPTIONS (WMT & WMD ONLY)

- N = No flow switch, in-line sensors
- L = Loose flow switch manifold, 20 ft cable, low pressure
- P = Flow switch manifold on PP panel, 5 ft cable, low pressure
- S = No flow switch, submersion sensors
- F = Loose flow switch manifold, 20 ft cable, high pressure
- H = Flow switch manifold on PP panel, 5 ft cable, high pressure

G ANALOG OUTPUTS (ALL MODELS)

- N = No analog outputs
- 1 - 4 = One to Four 4-20 mA output boards

H INPUT OPTIONS

- N = No input options
- A = 8 analog inputs
- D = 6 digital inputs
- B = Both analog and digital input cards

J COMMUNICATIONS HARDWARE (USB & ETHERNET STANDARD)

- N = No additional hardware
- M = Landline Modem
- G = GPRS Modem

K COMMUNICATIONS SOFTWARE

- N = No additional software
- 1 = Ethernet networking master capability
- 2 = Modbus TCP/IP
- 3 = Both Ethernet networking and Modbus TCP/IP



WALCHEM

An Iwaki America Company

Five Boynton Road
Hopping Brook Park Holliston, MA 01746 USA
Phone: 508-429-1110
Fax: 508-429-7433
www.walchem.com

180275.E Sep 2010